



H A Harman International Company

# C419

## Wind Instrument Micromic

### Description

The C419 Micromic is response tailored for use with both brass and woodwind instruments as a clip-on microphone. The microphone is small, light weight, and can be easily clipped onto the bell of an instrument and positioned for best pickup with its small gooseneck section. While it can be directly phantom powered, many engineers may want to use it in conjunction with an AKG wireless system to give the performer utmost freedom of movement on stage. The response has a gentle low frequency rolloff to compensate for proximity effect and a slight high frequency rise for added presence. External shock mounting offers excellent isolation. Its hypercardioid polar pattern gives the C419 additional isolation from floor monitors and other instruments.

### Specifications

<b>Transducer type:</b>	Condenser pressure gradient
<b>Frequency response</b>	20 Hz - 20 kHz
<b>Polar pattern:</b>	Hypercardioid
<b>Impedance:</b>	200 ohms
<b>Output connector:</b>	XLR, mini XLR (C419/L), or B-lock 1/8" threaded (C419/B)
<b>Sensitivity:</b>	7 mV/Pa; -43 dB (re 1 V)
<b>Powering:</b>	Phantom powering from 9 to 52 Vdc
<b>Sound pressure level for 1% /3% THD:</b>	126/130 dB
<b>Size:</b>	(7" x 1.4") including clamp (180 mm x 35 mm)
<b>Net weight:</b>	5.0 oz (141 g)
<b>Shipping weight:</b>	16.3 oz (462 g)
<b>Standard accessory</b>	W44 Windscreen
<b>Optional Accessories:</b>	B29 Battery operated phantom power supply with a 2 input mixer. (used with the C419/B version) WMS60, 80, 61, 81 wireless microphone system (used with the C419/L)

### Features

- External shock mounting for excellent isolation
- Rubberized clamp for simple and secure mounting
- Miniature gooseneck extension for precise placement
- Adaptable to phantom powering or wireless operation
- Hypercardioid pattern for good isolation from other players and floor monitors



# Architects and Engineers Specifications

The microphone shall be a condenser type with a hypercardioid pickup pattern with response from 20 Hz to 20 kHz. Sensitivity shall be no less than 7 mV/Pa, and the maximum operating level for 1 and 3% THD shall be 126 and 130 dB, respectively. The microphone shall be equipped with a rubberized clamp to facilitate attaching to the bell of a wind instrument without leaving a mark on the instrument. The microphone shall be adaptable to either

phantom powering over the range from 9 to 52 Vdc, or for direct use with a wireless transmitter worn by the user. The microphone dimensions shall be 7.086 x 2.08 inches, including the clamp, and the net microphone weight shall be no greater than 5.0 ounces. The microphone shall be the AKG Acoustics Model C419 (specify XLR or B-lock cord termination).

## Graphical Data

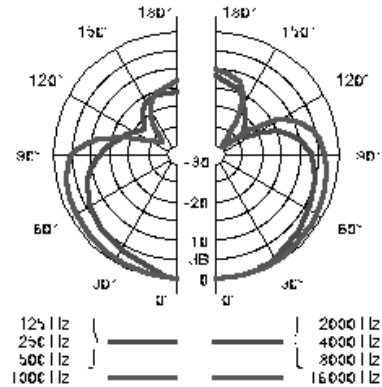
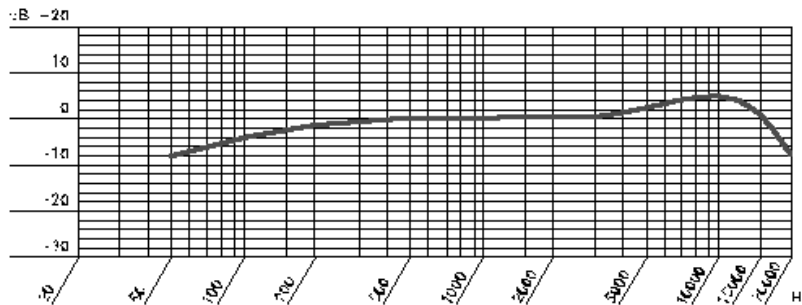

AKG is constantly improving and modifying its products, therefore, specifications are subject to change without notice.

### Limited Warranty

Valid only in the United States. AKG Acoustics warrants AKG products against defects in material or workmanship for a period of one year from the date of original purchase for use, and agrees to repair or, at our option, replace any defective unit without charge for either parts or labor. Important: This warranty does not cover damage resulting from accident, misuse or abuse, lack of reasonable care, the affixing of any attachment not provided with the product, loss of parts or connecting the product to any but the specified receptacles. This warranty is void unless service or repairs are performed by an authorized service center. No responsibility is assumed for any special, incidental

or consequential damages. However, the limitation of any right or remedy shall not be effective where such is prohibited or restricted by law. Simply take or ship your AKG product prepaid to our service department. Be sure to include your sales slip as proof of purchase date. (We will not repair transit damage under the no-charge terms of this warranty.) Note: No other warranty, written or oral is authorized by AKG Acoustics, Inc. This warranty gives you specific legal rights, and you may also have other rights which vary from state to state. Some states do not allow the exclusion or limitation of incidental or consequential damages or limitation on how long an implied warranty lasts, so the above exclusions and limitation may not apply to you..

Microphones · Headphones · Wireless Microphones · Wireless Headphones · Headsets · Electroacoustical Components



H A Harman International Company

**AKG Acoustics GmbH**  
Lemböckgasse 21-25, P.O.B. 158, A-1230  
Vienna/AUSTRIA  
Tel: (43 1) 86 654-0\*, Fax: (43 1) 86 654-516  
Internet: <http://www.akg-acoustics.com>

**AKG Acoustics;** A Division of Harman Pro Germany  
Bodenseestraße 228, D-81243 München/GERMANY  
Tel: (089) 87 16-0, Fax: (089) 87 16-200

**Arbiter Pro Audio**  
Wilberforce Road, London NW9 6AX/ENGLAND  
Tel: (0181) 202 1199, Fax: (0181) 202 7076

**AKG ACOUSTICS, U.S.**  
1449 Donelson Pike  
Nashville, TN 37217, U.S.A.  
Tel: (615) 360-0499, Fax: (615) 360-0275

**Studer Japan Ltd.**  
2-43-7, Uehara, Shibuya-ku, Tokyo 151-0064/JAPAN  
Tel: (813) 3465-2211, Fax: (813) 3465-2214

**Erikson Pro Audio**  
620 McCaffrey, St-Laurent, Quebec, H4T 1N1, CANADA  
Tel: (514) 738-3000, Fax: (514) 737-5069  
Internet: [www.jam-ind.com/eriksonpro](http://www.jam-ind.com/eriksonpro)