

ZOOM 504 ACOUSTIC Operation Manual

Thank you for selecting the **ZOOM 504** (hereafter simply called the "**504**").

Please take the time to read this manual carefully so you can get the most out of your 504 and ensure optimum performance and reliability.

Retain this manual for future reference.

ZOOM CORPORATION

NOAH Bldg., 2-10-2, Miyanishi-cho, Fuchu-shi, Tokyo 183-0022, Japan
PHONE: 0423-69-7116 FAX: 0423-69-7115

Printed in Japan 504-5000





1 Major Features

- New type of compact multi-effect device designed for creating great acoustic guitar sound.
- Suitable for use with an acoustic guitar or an electric guitar. Use the dedicated effects for acoustic guitar, or make an electric guitar sound like an acoustic guitar with the built-in simulator.
- Unique AIR effect imitates the sound as picked up by a microphone. Reverb and chorus effects help to create a spacious feeling. Enjoy life-like, dynamic sound even during line recording.
- Feedback suppressor automatically detects and attenuates problem frequencies. This makes the 504 useful not only for line recording but also on stage.
- Two input jacks with different sensitivity allow optimum matching to any type of guitar, from acoustic guitars with magnetic pickups to electric guitars with humbucking type pickups.
- You can switch between 24 patches to store diverse settings based on your preference.
- Integrated auto-chromatic tuner for guitar. You can tune your instrument easily anywhere, any time. You can also leave the tuning function disabled all the time.
- Dual power supply design allows the unit to be powered from a 9V alkaline battery (6LR61) or an AC adapter.

2 Safety Precautions

USAGE AND SAFETY PRECAUTIONS

In this manual, symbols are used to highlight warnings and cautions for you to read so that accidents can be prevented. The meanings of these symbols are as follows:

-  **Warning** This symbol indicates explanations about extremely dangerous issues. If users ignore this symbol and handle the device incorrectly, serious injury or death could result.
-  **Caution** This symbol indicates explanations about dangerous issues. If users ignore this symbol and handle the device the wrong way, bodily injury and damage to the equipment could result.

Please observe the following safety tips and precautions to ensure hazard-free use of the 504.

About power

Warning Since power consumption of this unit is fairly high, we recommend the use of an AC adapter whenever possible. When powering the unit from a battery, use only an alkaline type.

AC adapter operation

- Be sure to use only an AC adapter which supplies 9 V DC, 300 mA and is equipped with a "center minus" plug (Zoom AD-0006). The use of an adapter other than the specified type may damage the unit and pose a safety hazard.
- Connect the AC adapter only to an AC outlet that supplies the rated voltage required by the adapter.
- When disconnecting the AC adapter from the AC outlet, always grasp the adapter itself and do not pull the cable.
- If the unit is not to be used for a long time, disconnect the AC adapter from the outlet.

Battery operation

- Use only a 9 V (alkaline) battery (6LR61).
- The 504 cannot be used for recharging. Pay close attention to the labelling of the battery to make sure you choose the correct type.
- If the 504 is not to be used for an extended period of time, remove the battery from the unit.
- If battery leakage has occurred, wipe the battery compartment and the battery terminals carefully to remove all remnants of battery fluid.
- While using the unit, the battery compartment cover should be closed.

Environment

Caution Avoid using your 504 in environments where it will be exposed to:

- Extreme temperature
- High humidity or moisture
- Excessive dust or sand
- Excessive vibration or shock

Handling

Caution The 504 is a precision instrument. Except for the foot switches, do not push other parts with your feet or subject them to strong force.

- Take care that no foreign objects (coins or pins etc.) or liquids enter the unit.
- Be sure to turn the power to all equipment off before making connections.
- Before moving the unit, turn the power off and disconnect all cables and the AC adapter.

Alterations

Caution Never open the case of the 504 or attempt to modify the product in any way since this can result in damage to the unit.

Usage precautions

Electrical interference

For safety considerations, the 504 has been designed to provide maximum protection against the emission of electromagnetic radiation from inside the device, and from external interference. However, equipment that is very susceptible to interference or that emits powerful electromagnetic waves should not be placed near the 504, as the possibility of interference cannot be ruled out entirely.

Whatever the type of digital control device, the 504 included, electromagnetic damage can cause malfunctioning and corrupt or destroy data. Since this is an ever-present danger, thorough care should be taken to minimize the risk of damage.

Cleaning

Use a soft, dry cloth to clean the 504. If necessary, slightly moisten the cloth. Do not use abrasive cleanser, wax, or solvents (such as paint thinner or cleaning alcohol), since these may dull the finish or damage the surface.

Connecting cables and input and output jacks

You should always turn off the power to the 504 and all other equipment before connecting or disconnecting any cables. Also make sure to disconnect all cables and the AC adapter before moving the 504.

3 What Are Banks and Patches?

• PATCH

A group of the settings for a certain effect type is called a PATCH. The 504 comes with 24 preset patches which can be changed (edited) by the user.

• BANK

The 504 calls up patches in sets of four, called a "bank".

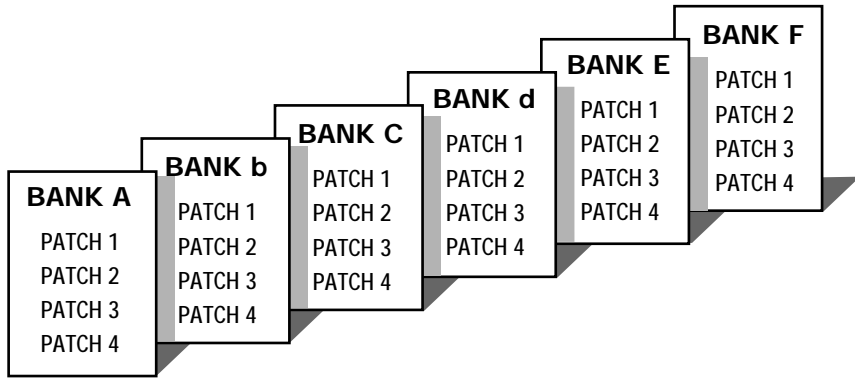

4 PATCH LIST

The 504 has memory capacity for 24 patches. At the factory, these are programmed with recommended settings.

The user can Edit and Store any patch, and also restore the factory settings.

HINT The patches of banks A through d for acoustic guitar are designed for line output to a mixer or similar. When using a guitar amplifier, it is recommended to adjust the De-Amp parameter.

BANK A - d for ACOUSTIC GUITAR

BANK A DEMO	1	Acoustic Master	Basic Acoustic sound with short reverberation
	2	Spacy-12	Simulated 12-string sound
	3	Gut Style	Gut string simulation, good for solo play
	4	Studio Strum	Recording quality sound for strum
BANK b WORLD	1	J-Folk	Folk guitar sound
	2	Hawaiian Steel	Simulated Lap-steel guitar sound
	3	Street Blues	Tight sound with room ambience
	4	Asian Dream	SFX making sound like ethnic instruments
BANK C PLAY	1	Studio Finger	Recording quality sound for finger picking
	2	Slide (Bottle)	Doubling sound for bottle-neck play
	3	Ragtime	Natural sound with delay and reverb
	4	Resonator	Simulated "Dobro" sound
BANK d ARTIST	1	Green Flavor	Freddie Green sound
	2	Arpeggian	Bright Arpeggio sound
	3	Virtuoso	Warm jazz guitar sound
	4	Avant-Garde	Progressive acoustic sound

BANK E, F ACOUSTIC SIMULATION for ELECTRIC GUITAR

BANK E DEMO	1	Standard	Standard acoustic simulation sound
	2	El-Acorustic	Piezo type electric-acoustic sound
	3	Warm Taste	Nylon-string type solo sound
	4	T2-Plus	Octave enhanced sound, good for solo and arpeggio
BANK F STYLE	1	Jumbo Type	Jumbo body sound
	2	Stage Strum	Useful acoustic simulation sound
	3	New-Strings	Bright acoustic sound
	4	Rich Strum	Acoustic 12-string simulation

*ACOUSTIC SIMULATION is suitable for single pickup at front position.

5 Configuration of Patches

The patches of the 504 are created using the nine parameters listed below. A parameter is an element that determines a certain aspect, such as the sound character or the effect intensity. Parameters can be altered by the user as desired, and a set of changed parameters can be stored as a patch for later recall.

Global parameters are common to all patches.

For an explanation of the function of each parameter, please refer to section "11. Editing Patches".

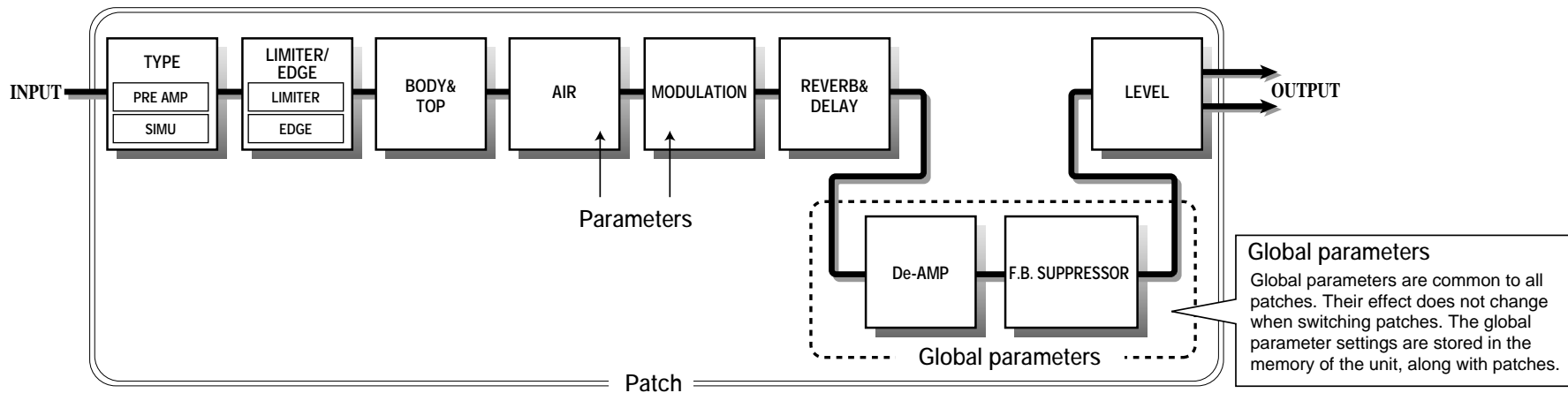

6 Controls, Functions and Connections

Front Panel

TUNER indicator

• Bypass(Mute)/Tuner mode

Indicator shows that tuning function is active and also serves to show the correct fine tuning position.

• Edit mode

Indicator flashes when LEVEL parameter (overall patch level) is selected.

• BATTERY EMPTY WARNING display

When the unit is powered from the battery and the battery is running low, this indicator begins flashing at a faster rate than in Edit mode. In such a case, replace the battery as soon as possible.

STORE key

When the contents of patches are to be stored, this key is used for putting the unit in store standby status and to execute the store function.

• Setting of direct load function

When the STORE key is pressed for at least 1 second during Play mode (during performance), the direct load function can be switched on or off. [For details, see 10 Patch Switching (Application: Direct Load OFF).]

EDIT key (for creating your own patches)

This key serves to toggle between the Play mode and Edit mode (mode for creating patches to suit your taste).

In Edit mode, this key can be used to select the effect parameters you wish to change. Also, when the effect parameter LEVEL is selected, press this EDIT key to return from the Edit mode to the Play mode.

• Setting of bank hold function

When the EDIT key is held down for at least 1 second in Play mode, the bank hold function is turned on or off. [For details, see 9 Patch Switching (Application: Bank Hold ON).]

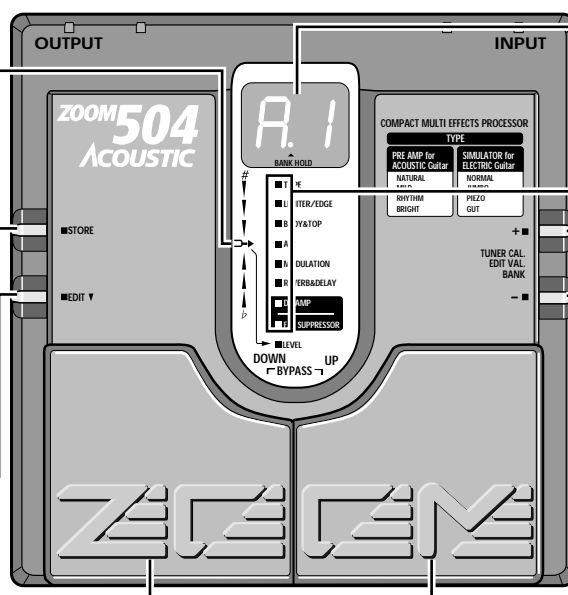

DISPLAY

Displays information required to operate the 504.

• Play mode

Displays the selected bank (A-F) and patch (1-4).

• Edit mode

Displays the value of the selected effect parameter.

• Bypass(Mute)/Tuner mode

Shows the pitch of the input signal.

PARAMETER CURSOR indicator

The currently used effect module lights.

• Edit mode

The indicator lights up for the currently used effect module, and the indicator flashes for the effect module that is turned off. Also, the indicator for the effect module selected for editing flashes.

• Bypass(Mute)/Tuner mode

Indicators function as tuning meter.

VALUE +/- keys

• Play mode

The keys serve for bank switching.

• Edit mode

The keys serve for changing the effect parameter.

• Bypass(Mute)/Tuner mode

The keys serve for setting the tuner reference pitch (calibration).

PATCH UP (right)/DOWN (left) pedals

• Play mode

The pedals serve for patch switching. Pressing both pedals simultaneously activates the Bypass(Mute)/Tuner mode.

• Edit mode

The pedals serve for selecting effect parameters. Pressing both pedals simultaneously turns the currently selected effect module on or off.

• Bypass(Mute)/Tuner mode

Pressing either pedal cancels the Bypass(Mute)/Tuner mode to return to Play mode.

Rear Panel

INPUT jack

Serves for connection of an acoustic or electric guitar. Choose the HIGH or LOW input, according to the output level of the pickup.

• HIGH:

For electric guitars with single-coil pickups or acoustic guitars with magnetic pickups.

• LOW:

For electric guitars with humbucking or active type pickups, or for electroacoustic guitars.

When the unit operates on batteries, the INPUT jack doubles as a power switch. Plugging in a shielded cable turns the 504 on. To prevent draining the battery, unplug the cable when the unit is not in use.

DC IN (AC adapter) jack

Serves for connecting an AC adapter (Zoom AD-0006) which delivers 9 VDC, 300 mA with a "center minus" plug configuration. The 504 is powered on by plugging an AC adapter into this jack.

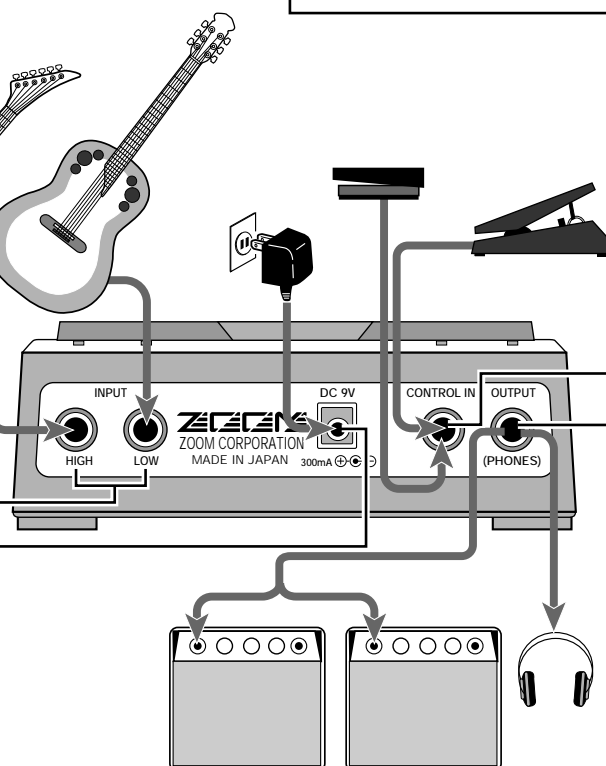

CONTROL IN jack

The optional FP01 expression pedal or FS01 foot switch can be connected here, for external control of the 504. When the expression pedal FP01 is connected, the pedal controls the output level. When the foot switch FS01 is connected, the switch turns the F.B.SUPPRESSOR function on and off. For a detailed explanation, please refer to section "12. Effect Parameters".

NOTE:

Before connecting or disconnecting the FP01 or FS01, make sure that the 504 is switched off. Otherwise malfunction can occur.

OUTPUT jack

This jack is for the output signal from the 504. You can connect either a single guitar amplifier, using a monaural shielded cable, or two guitar amplifiers, using a Y-type stereo shielded cable, or a pair of stereo headphones. If the volume level is low when using headphones, use headphones with low impedance (32 ohms or less).

7 Selecting Patches

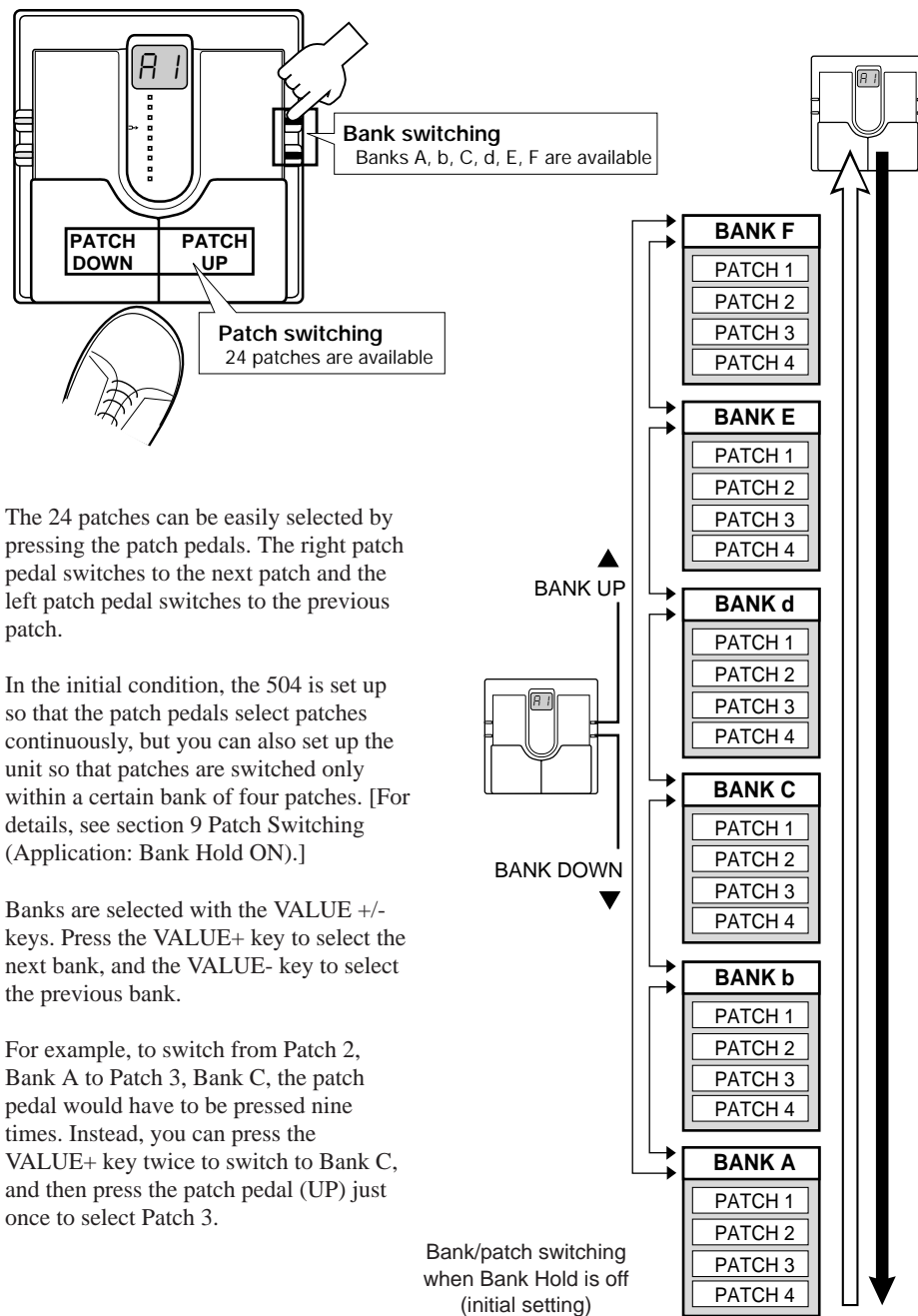

The 24 patches can be easily selected by pressing the patch pedals. The right patch pedal switches to the next patch and the left patch pedal switches to the previous patch.

In the initial condition, the 504 is set up so that the patch pedals select patches continuously, but you can also set up the unit so that patches are switched only within a certain bank of four patches. [For details, see section 9 Patch Switching (Application: Bank Hold ON).]

Banks are selected with the VALUE +/- keys. Press the VALUE+ key to select the next bank, and the VALUE- key to select the previous bank.

For example, to switch from Patch 2, Bank A to Patch 3, Bank C, the patch pedal would have to be pressed nine times. Instead, you can press the VALUE+ key twice to switch to Bank C, and then press the patch pedal (UP) just once to select Patch 3.

8 Using the Bypass (Mute)/Tuner Mode

In the Bypass mode, the effects of the 504 are temporarily turned off, so that the original sound of the instrument only is heard. In this mode, the auto-chromatic tuning function is also active. It is also possible to activate muting, to prevent the tuning sound from being sent to the output.

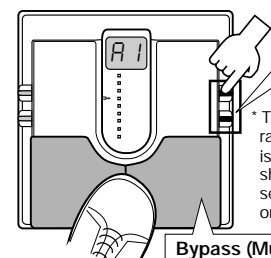

Calibration
Select reference pitch for auto-chromatic guitar tuner (calibration).

The reference pitch (A) can be adjusted in the range from 435 to 445 Hz. When the BANK key is pressed in Bypass (Mute)/Tuner mode, this is shown as "35" to "45" on the display for a second. Adjust to the suitable value. At power-on, the setting is 440 Hz (40).

Bypass (Mute)/Tuner mode ON
Pressing both patch pedals simultaneously turns the Bypass (Mute)/Tuner mode on. To turn the mode off, simply press one of the two patch pedals.

Bypass and mute condition

Pressing both patch pedals simultaneously activates the Bypass or Mute mode.

- **For bypass mode:** Press and immediately release the patch pedals.



- **For mute mode:** Press patch pedals for at least 1 second.

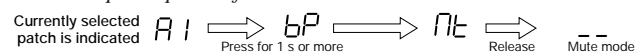

To cancel the bypass or mute condition, simply press one of the patch pedals. The unit then reverts to the previously selected patch.

Tuner mode

The 504 is initially set so that the auto-chromatic tuning function for the guitar activates automatically when the Bypass(Mute) mode is invoked. In Bypass(Mute) mode, pick an open string to be tuned. The closest note will be shown on the display.

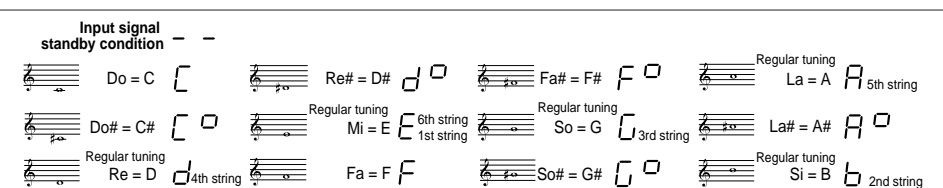

When the tuning function is active, the parameter cursor LEDs serve as tuning meter, designed to enhance tuning precision during fine adjustments.

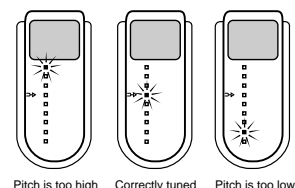

Turning tuning function off

If you do not want to activate the tuning function in Bypass(Mute) mode, press the STORE and EDIT keys simultaneously for more than one second in Play mode. The tuning function will be turned off, and this setting will be stored even when the power is turned off. When you turn the function off, the display will show "tunEr OFF" (tuning function off).

To turn the tuning function on, press the same keys simultaneously again. The display will show "tunEr on" (tuning function on).

NOTE: Please note that the tuning function may not operate properly if other effect modules between the guitar and the 504 are on.

9 Patch Switching (Application: Bank Hold ON)

In the initial setting, the patch pedal switches all patches in order, regardless of the bank divisions.

The bank hold function limits switching to the four patches within a bank. When this function is activated, the patch pedals switch in order between the patches in the current bank only.

To activate this function, hold the EDIT key down for at least 1 second in Play mode. The BANK HOLD indicator will light. To turn the function off, again hold the EDIT key down for at least 1 second. The BANK HOLD indicator will go off.

Banks can be switched using the VALUE +/- keys.

Bank Hold ON
Keeping the EDIT key depressed for at least 1 second activates Bank Hold. To cancel Bank Hold, press the EDIT key again for 1 second.

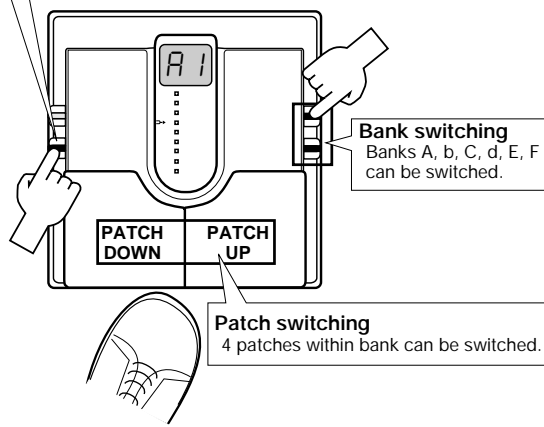

Bank/patch switching when Bank Hold is on

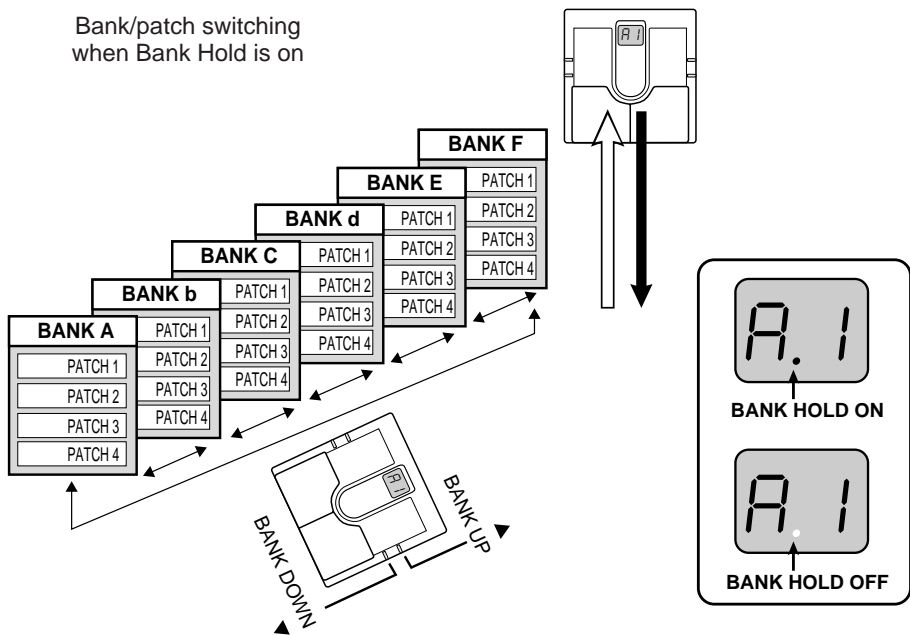

10 Patch Switching (Application: Direct Load OFF)

In the default condition, the 504 is set up in such a way that pressing a patch pedal immediately switches the patch and alters the output sound. This is called Direct Load ON. This switching principle is most convenient when the desired patches are adjacent or close to each other. However, when wanting to switch to a patch that is further away, it may be desirable not to activate the sound of the other patches in between.

When this is desired, turn the Direct Load function off as follows. When Direct Load has been turned off, switching banks and patches has no effect until the user confirms the selection.

For example, when going from patch 1 to patch 4 with Direct Load active, patches 2 and 3 will briefly be heard when the patch UP pedal is pressed three times. When Direct Load is off, pressing the patch UP pedal will change the number on the display (the number flashes), but until the user confirms the choice, the sound remains that of patch 1.

To turn Direct Load on or off, keep the STORE key depressed for at least 1 second. To confirm a choice after selecting a patch with Direct Load off, press both patch pedals simultaneously.

DIRECT LOAD OFF
Keeping STORE key depressed for 1 second turns Direct Load off. The same procedure serves to turn it on.

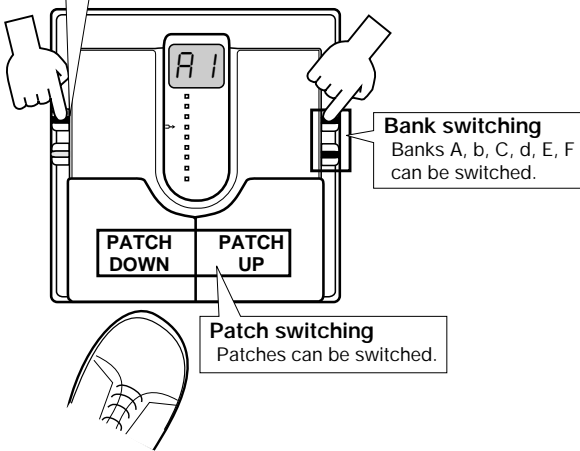

Confirming a patch
When display indication flashes, pressing both patch pedals together confirms the patch and switches the output sound.

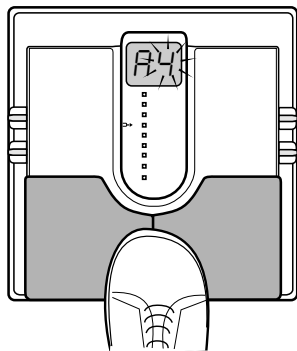

Press both pedals together

Example: Switching from patch 1 to patch 4

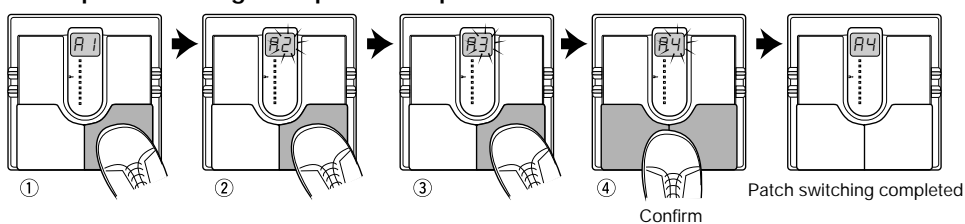

11 Editing Patches

The 504 comes with 24 predefined patches. However, the 504 offers many more possibilities for combining effects in innovative ways. To discover these possibilities, we recommend that you try changing the parameters (elements that make up patches) to create your own patches. This operation is called editing, and is done in the Edit mode.

To switch from normal Play mode to Edit mode, press the EDIT key briefly (for less than 1 second).

*** Note that if the EDIT key is held down for 1 second or longer, the Bank Hold mode will be activated.**

Immediately after switching from Play mode to Edit mode, the TYPE parameter cursor is flashing, and the TYPE setting is shown on the display. This indicates that the TYPE parameter is currently selected for editing.

In Edit mode, the EDIT key or PATCH UP/DOWN pedals are used to select the parameter for editing. The 504 has the following parameters:

- **TYPE:** Selects the preamp module type. Make the selection according to the connected type of guitar and the desired application.
- **LIMITER/EDGE:** Depending on the setting of the TYPE parameter, this parameter enhances the edge of the guitar string sound or compresses the dynamic range.
- **BODY & TOP:** Emphasizes the lower frequency range (BODY) or upper frequency range (TOP), causing a voluminous sound or making the sound brighter and more distinct.
- **AIR:** Simulates sound as if captured with a microphone.
- **MODULATION:** Lends a soft expansive feeling to the sound, using a chorus effect. Depending on the parameter setting, an octave-higher component can be added, to emulate the sound of a 12-string guitar.

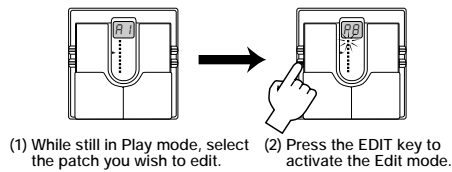

- **REVERB & DELAY:** Adjusts the reverberation effect. Depending on the parameter setting, a mix of delay and reverb can be created to increase the depth of the sound.
- **De-AMP:** Serves to control the frequency range that can be sonically unpleasant when reproducing the sound of an acoustic guitar over an electric guitar amplifier.
- **F.B.SUPPRESSOR:** Reduces feedback which can occur easily when using an acoustic guitar during a live performance.
- **LEVEL:** Adjusts the overall level of the patch.

Each push of the EDIT key moves the blinking parameter cursor indicator one step down. The TUNER indicator serves as parameter cursor for the LEVEL parameter. When the EDIT key is pressed while the lowest indicator (F.B.SUPPRESSOR) is flashing, the TUNER indicator starts flashing and the LEVEL parameter can be adjusted.

The parameter value is changed using the VALUE +/- keys. For details on parameters, please refer to section "12. Effect Parameters".

To terminate the Edit mode and return to the Play mode, press the EDIT key while the LEVEL parameter is selected (TUNER indicator is flashing). For information on how to store changed parameters, please refer to section "13. Storing Patches".

When the PATCH DOWN pedal is pressed instead of the EDIT key, the TYPE parameter is selected again and the unit does not return to the Play mode.

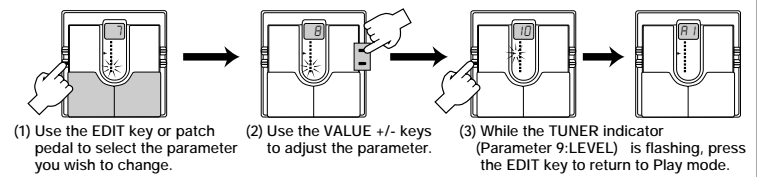

12 Effect Parameters

PARAMETER 1 : TYPE

When using an acoustic guitar, this parameter serves for making preamplifier settings. When using an electric guitar, the parameter serves for making acoustic guitar simulator settings.

Pressing one of the VALUE +/- keys increases or decreases the setting by one step.

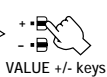

PARAMETER 2 : LIMITER / EDGE

Depending on the setting of the TYPE parameter, this parameter either controls the dynamic range or the sharpness of the sound.

Increases or decreases the setting by 1.

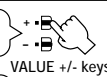

Skips to 10 if current setting is 1 - 9, and to 15 if 10 - 14.

PARAMETER 3 : BODY & TOP

This parameter adjusts the lower frequency range (BODY) or upper frequency range (TOP).

Increases or decreases the setting by 1.

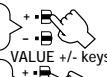

Skips to 11 if current setting is b1 - b9, and to E1 if 11 - 19.

PARAMETER 4 : AIR

This parameter imitates the way a guitar sounds when picked up by a microphone.

Increases or decreases the setting by 1.

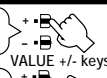

Skips to 10 if current setting is 1 - 9.

PARAMETER 5 : MODULATION

This parameter lends a wide, spacious feeling to the sound.

Increases or decreases the setting by 1.

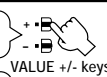

Skips to c1 if current setting is C1 - C9, to t1 if c1 - c9, etc.

PARAMETER 6 : REVERB & DELAY

This parameter adds reverb and delay to the original sound.

Increases or decreases the setting by 1.

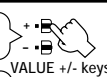

Skips to S1 if current setting is L1 - L9, to d1 if S1 - S9, etc.

PRE AMP for ACOUSTIC Guitar

When using an acoustic guitar, select one of the settings na, Md, ry, br. These settings control the dedicated acoustic guitar preamplifier, each giving a different sound character. Choose the setting that is best matched to your playing style.

na (natural): Md (mild): ry (rhythm): br (bright):

na

Natural sound suitable for almost any genre and playing style.

Md

Changes even the sound of piezo pickups to a warm sound.

ry

Tight sound best suited for stroke playing.

br

Bright sound best suited for fingering.

When one of the settings na, Md, ry, br (for acoustic guitar) is selected for the TYPE parameter, the LIMITER/EDGE parameter works as a limiter that compresses the dynamic range.

Controls the limiter intensity. Larger values result in stronger limiter effect (more narrow dynamic range).

* The limiter can be adjusted also when the TYPE parameter is off.

Increasing the BODY value results in a more voluminous sound, and increasing the TOP value makes the sound brighter and more distinct.

Adjusts the lower frequency range (BODY). Higher values result in more voluminous sound.

Adjusts the upper frequency range (TOP). Higher values result in brighter sound.

Simultaneously adjusts the lower frequency range (BODY) and upper frequency range (TOP). Higher values result in a more pronounced effect.

* The effect of the BODY & TOP parameter differs, depending on whether a setting for acoustic guitar (na, Md, ry, br) or electric guitar (nr, Jb, PE, Gt) is selected for the TYPE parameter.

SIMULATOR for ELECTRIC Guitar

When using an electric guitar, select one of the settings nr, Jb, PE, Gt. These settings control the acoustic guitar simulator which makes an electric guitar sound like an acoustic guitar. Each setting gives a different sound character.

nr (normal): Jb (jumbo): PE (piezo): Gt (gut):

nr

Simulates the sound of a traditional acoustic guitar.

Jb

Simulates the sound of a large-bodied acoustic guitar.

PE

Simulates the sound of an acoustic guitar with a piezo pickup.

Gt

Simulates the sound of a classical guitar with nylon strings.

When one of the settings nr, Jb, PE, Gt (for electric guitar) is selected for the TYPE parameter, the LIMITER/EDGE parameter works as an EDGE effect that enhances the sharpness of the guitar string sound.

Controls the EDGE effect. Larger values result in more pronounced string sound.

Global parameters

PARAMETER 7 : De-AMP

This parameter serves to control the frequency range that can be sonically unpleasant when reproducing the sound of an acoustic guitar over an electric guitar amplifier.

Increases or decreases the setting by 1.

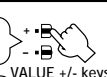

Skips to c1 if current setting is b1 - b9, to S1 if c1 - c9, etc.

When using an electroacoustic guitar, depending on the amplifier and pickup type, certain frequency ranges can sound unpleasant or grating to the ear. By adjusting the De-AMP parameter, this phenomenon can be reduced. The following three setting ranges are available. Choose one that is most effective for your playing technique.

Reduces certain offending frequencies likely to occur with a bright combo type guitar amplifier. Higher values result in more effective suppression.

Reduces certain offending frequencies likely to occur with a combo type guitar amplifier. Higher values result in more effective suppression. The frequency range differs from the b1 - b9 settings.

Reduces certain offending frequencies likely to occur with a stack type guitar amplifier. Higher values result in more effective suppression.

* The De-AMP parameter is a global parameter which works on all patches.

PARAMETER 8 : F.B. SUPPRESSOR

This parameter serves for suppressing feedback which can occur when using an acoustic guitar during a live performance. The frequency range for the parameter can be selected.

Increases or decreases the setting by 1.

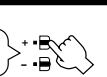

Skips to 1 if current setting is SC, to 10 if 1 - 9, to 20 if 10 - 19, etc.

Feedback is reduced by attenuating a selectable frequency range (feedback frequency). The frequency range can be selected either automatically or manually.

This setting serves to automatically detect the feedback frequency while playing. By selecting "SC" when feedback occurs, the frequency is detected (this process requires about one second), and attenuation is then applied automatically.

The detection occurs whenever the setting is switched to

"SC" from the "1" setting, or if the F.B.SUPPRESSOR parameter is turned from off to on (by pressing the PATCH UP/DOWN pedals simultaneously), with "SC" selected.

While the frequency is being detected, the parameter cursor flashes and the pedals and keys of the unit are inactive.

Allows manually adjusting the feedback suppression range. The higher the setting, the higher the feedback frequency.

* The F.B.SUPPRESSOR parameter is a global parameter which works on all patches.

PARAMETER 9 : LEVEL

This parameter serves to adjust the overall level of the patch.

Increases or decreases the setting by 1.

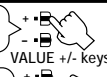

Skips to 10 if 1 - 9, to 20 if 10 - 19, etc.

The higher the setting, the higher the overall patch level.

HINT 1 Selection of parameters to change

As described in 11. Editing Patches, parameters to be edited are selected by repeatedly pressing the EDIT key, but you can also use the patch pedals for this purpose.

Press the PATCH UP pedal (right patch pedal) to move the parameter cursor from the bottom up.
Press the PATCH DOWN pedal (left patch pedal) to move the parameter cursor from the top down.

HINT 2 Switching parameters on and off

Except for LEVEL, any selected parameter can be turned on or off by pressing the PATCH UP/DOWN pedals simultaneously. The on/off condition can also be stored as part of the patch.

To switch a parameter on or off:
When any parameter except LEVEL is selected in the Edit mode, pressing the PATCH UP/DOWN pedals simultaneously turns the parameter off. (The indication "oF" appears on the display.) The parameter can be

turned on again either by pressing the PATCH UP/DOWN pedals simultaneously once more, or by pressing one of the VALUE +/- keys. The parameter setting that was active before will be reestablished.

When the F.B.SUPPRESSOR parameter is set to "SC", turning the parameter off and on again will cause the automatic feedback frequency detection to be performed once more. The frequency setting therefore may be different after the parameter is turned on again.

HINT 3 Parameter setting shortcuts

Normally, parameter values are set by tapping the VALUE + or VALUE - key once for each increment or decrement. For quick operation, you can use the shortcut function. This is activated in the Edit mode by pressing both VALUE keys together.

For example, if the LEVEL parameter is set to "20" and you want to change it to "29", you would have to press the VALUE + key 9 times. Instead, you can achieve the same effect by using the shortcut function: press the VALUE +/- keys together, which will change the value to "30" and then press the VALUE - key once to arrive at "29".

HINT 4 Using the F.B.SUPPRESSOR

(1) **Detecting feedback frequency automatically in Edit mode**
Select a different setting for F.B.SUPPRESSOR and then select "SC", or turn the parameter off and then on again while "SC" is selected.

(2) **Adjusting feedback frequency manually in Edit mode**
If feedback attenuation in "SC" mode is not satisfactory, try setting the F.B.SUPPRESSOR parameter manually to a value between 1 and 30 to find the setting which yields optimum suppression.

(3) **Detecting feedback frequency automatically in Play mode**
In order to be able to automatically detect the feedback frequency while playing the guitar, you must first set the F.B.SUPPRESSOR parameter to "SC". In Play mode, you can then turn the parameter off and on again by pressing the foot switch FS01 twice. The feedback frequency will be detected automatically, and suppression will be active.

* During the detection interval (about one second), do not turn down the guitar volume or change other settings.
* If the F.B.SUPPRESSOR parameter is set to 1 - 30, switching the

parameter off and on again will not cause automatic feedback frequency detection.

* In either case, the F.B.SUPPRESSOR parameter setting will be stored when the currently selected patch is stored.

HINT 5 Master level adjustment

With the 504 you are also able to set the master level that governs the overall output level.

The master level is adjusted in Play mode. Hold the VALUE +/- keys down simultaneously for at least 1 second. The current master level will be displayed for 1 second.

While the level is being displayed, use the VALUE +/- keys to change it. The setting range is 0 - 50. (Default value = 40)

The unit does not store the setting for the master level. Each time the power is turned on it has to be set again.

13 Storing Patches

If you have edited (altered) a patch and turn the 504 off without storing the patch, the patch will revert to its old setting. To store an edited patch, use the following simple procedure.

Storing can be carried out in both Play mode and Edit mode.

After you have edited the patch, press the STORE key. If the unit is currently in Play mode, release the key before 1 second has elapsed, otherwise the Direct Load function will be activated.

The display starts to flash. This condition is called the store standby condition. If you wish, you can abandon the store procedure at this point by pressing the EDIT key. If you press the STORE key once more, the contents of the patch are updated.

You can also change the patch number before storing, so that the edited patch will be stored in a different number.

In this case, the original patch that was used as a starting point for editing will not be changed.

NOTE
When a patch is stored, the current settings of the global parameters (De-AMP, F.B.SUPPRESSOR) are also stored. If the parameter settings were changed and the unit is turned off without storing the patch, the parameters will revert to the old settings.

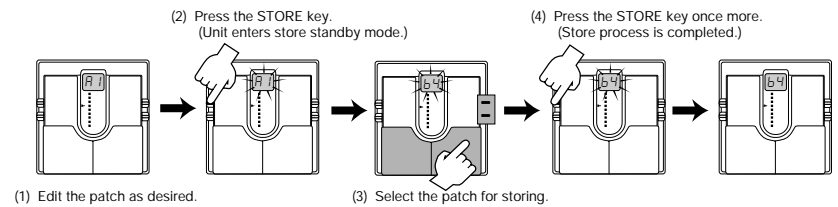

14 Replacing the Battery

If the tuning indicator flashes while the unit is being powered from the battery, the battery is exhausted and should be replaced as described below.

Use only a 6LR61 9 V (alkaline) battery.

Using another kind of battery will result in shorter operation.

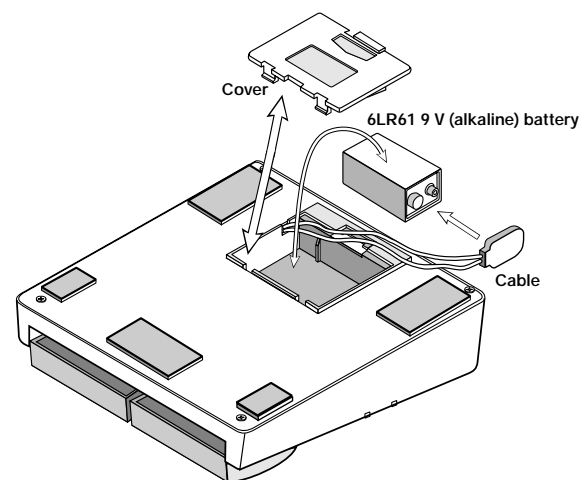

1. Turn the 504 upside down and open the cover of the battery compartment. (Push the catch to unlock the cover, then lift it up.)
2. Remove the battery from the compartment and disconnect the battery cable. (Grasp the terminal strip and do not pull at the cable.)
3. Connect the battery cable to the new battery, taking care to observe correct polarity (+/-). Then insert the battery into the battery compartment.
4. Close the battery compartment cover, taking care not to pinch the cable. (Make sure that the cover is properly locked.)

15 Returning Patches to Factory Settings

The 504 comes with 24 predefined patches that have been programmed at the factory. Also after you have edited and stored your own patches, you can return to the factory default settings at any time. This process is called "recalling". Returning all 24 patches to the original contents and resetting the Bank Hold and Direct Load functions is called "all initialize".

The Recall mode is separate from the Play mode and Edit mode. You cannot switch directly to Recall mode from these modes. The Recall mode can only be activated by turning the unit on in a special way, as described below.

1. Turn the unit off by disconnecting the AC adapter or the guitar input cable.
2. Keep the STORE key depressed and turn the unit on.
3. The indication "AL" flashes on the display.
4. To perform "all initialize", press the STORE key once more in this condition. The flashing rate increases and the initialization procedure is carried out. When it is completed, the unit automatically enters the Play mode.
5. When wishing to recall only a particular patch, select the patch number in step 3, using the same procedure as for normal patch selection.
6. When the desired patch has been selected, press the STORE key. The flashing rate increases and the contents of the selected patch are recalled.
7. Recalling of individual patches can be carried out continuously. When you wish to terminate the process, press the EDIT key. The unit then returns to the Play mode. Turning the unit off also terminates the recall condition.

16 Specifications

Effects:	26 effects • TYPE PRE AMP (for ACOUSTIC GUITAR) ACOUSTIC SIMULATOR (for ELECTRIC GUITAR) • LIMITER (TYPE:PRE AMP,TYPE OFF) EDGE (TYPE:ACOUSTIC SIMULATOR) • BODY&TOP •AIR •MODULATION • REVERB&DELAY •De-AMP •F.B. SUPPRESSOR Maximum simultaneous effects:8
Banks and Patches:	6 banks X 4 patches = 24 patches (edit + store possible)
Analog/Digital Conversion:	18 bit,128 times oversampling
Digital/Analog Conversion:	16 bit, linear
Sampling Frequency:	31.25 kHz
Inputs:	HIGH input (standard monaural phone jack) Input impedance: 470kilohms Rated input level: Electric Guitars with single-coil pick ups Acoustic Guitars with magnetic pick ups LOW input (standard monaural phone jack) Input impedance: 470kilohms Rated input level: Electric Guitars with hum-bucking typ active type Electric Acoustic Guitar
Output:	Combined line/headphone output(stander stereo phone jack) Max. output level: +6 dBm Output load impedance: 10 kilohms or more For optional FP01 or FS01
Control Input:	
Display:	2-digit,7-segment LED,tuning indicator,parameter cursor indicator
Power Requirements:	Optional AC adapter 9 VDC,300mA (ZOOM AD-0006) Battery: 6LR61 9V (alkaline) battery X 1 Battery life: Approx. 4h continuous operation
Dimensions:	147(W) X 157(D) X 49(H) mm
Weight:	480 g (without batteries)

* 0 dBm = 0.775 Vrms

* Design and specifications subject to change without notice.